



Standard Access Structures

Ramp, Walkways, Covers, and Stairs Catalogue



About FRP

The unique characteristics of composites make them suited for an immense variety of uses, including the civil and public infrastructure, marine, aerospace, petroleum and many more.

At Terra Firma Industries, we're passionate about modern composite materials. That's why we developed our TerraGrate FRP range.

TerraGrate FRP (Fibre Reinforced Polymer/Plastic)

is lighter and stronger than equivalent traditional materials. As a result, FRP sheeting offers massive time and cost savings during installation and maintenance. TerraGrate FRP does not corrode, rot or burn and can be easily fabricated on site using common hand tools. It's perfect for use in exposed, corrosive and chemical environments to reduce costs and improve safety.

TerraGrate FRP offers a range of benefits over traditional materials:



Lightweight



Strong



Improved OH&S



Corrosion resistant



Fire resistant



Chemical resistant



Non-conductive



Slip resistant



Cost effective



Design friendly



Durable



Colour stable

Because FRP is made by combining a matrix of resins and fibres. The resins can be tailored to meet very specific requirements including chemical, electrical, fire or slip-resistance and the fibres can be chosen for different strength and flexibility ratings.

TerraGrate offers a full range of FRP products including walkway and platform mesh, support pedestals, handrails, stairs, anti-slip flooring, marine-grade walkway and structural profiles.



Standard Access Structures



Fiberglass Reinforced Plastic (FRP) is transforming outdoor access structures with its sustainability, durability, and cost-efficiency.

Terra Firma FRP and Glass Reinforced Plastic (GRP) products provide standard pre-fabricated solutions for outdoor access structures, including walkways, ramps, covers, and stairs.

For environments where there are challenges such as time and distance limitation, weather dependency and narrow installation windows, pre-fabricated products assembled off site offer fast and easy installation solutions.

With no cutting on site required, simple assembly and integrated height adjustment, Terra Firma pre-fabricated access structures can turn a seven-day project into a one-day job, saving considerable time and money.



Standard Access Structures

Ramp

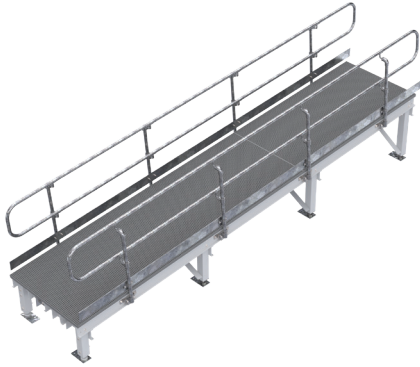

Dimensions: 6m x 1.2m

Walkway 1.2m

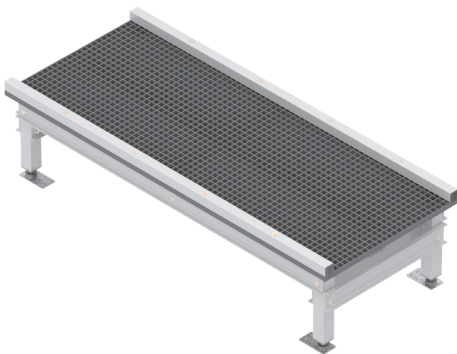

Dimensions: 1.2m x 3m

Walkway 2.4m

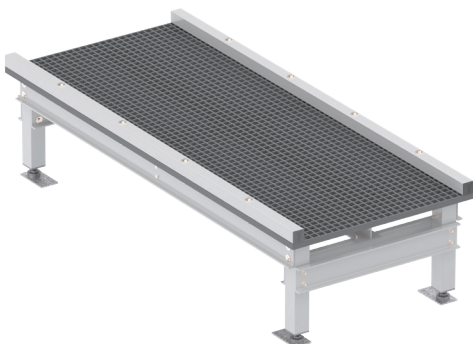

Dimensions: 2.4m x 3m



Standard Access Structures

Stairs - Single Step

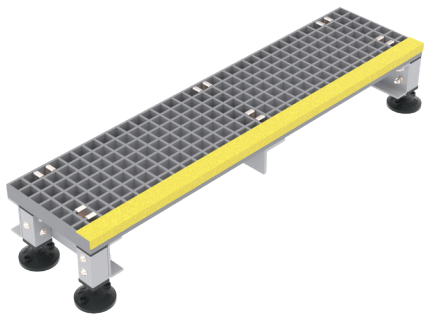

Dimensions: W 1.2m
H 200mm - 300mm

Stairs - 2 Steps 1.2m



Dimensions: W 1.2m
H 400mm - 500mm

Stairs - 2 Steps 2.4m

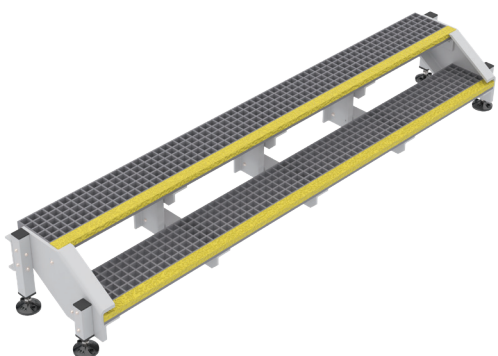

Dimensions: W 2.4m
H 400mm - 500mm



Standard Access Structures

Stairs - 3 Steps 1.2m



Dimensions: W 1.2m
 H 500mm - 600mm

Stairs - 5 Steps 1.2m



Dimensions: W 1.2m
 H 900mm - 1000mm

Adjustable Walkway Cover

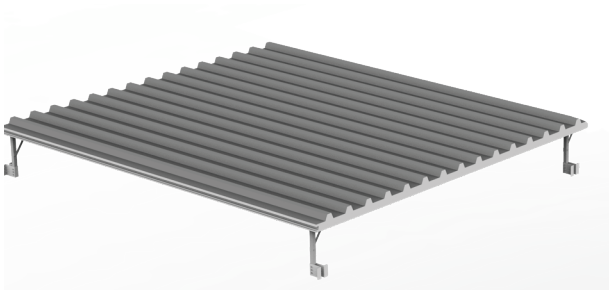

Dimensions: L 3m
 W 2.4m



Terra
Firma™

Phone: 1800 PITLIDS (1800 748 543)

Email: info@tfpl.com.au

139 Somerset Rd,
Campbellfield Victoria 3061 Australia

terrafirmaindustries.com.au